

ORDINANCE NO. \_\_\_\_

**AN ORDINANCE VACATING AND ABANDONING A STREET-RAILROAD CROSSING ON 14<sup>TH</sup> STREET OVER THE UNION PACIFIC RAILROAD IN THE CITY OF NORTH LITTLE ROCK; AUTHORIZING THE MAYOR & CITY CLERK TO ENTER INTO A RAILROAD HIGHWAY CLOSURE AGREEMENT; DECLARING AN EMERGENCY; AND FOR OTHER PURPOSES.**

WHEREAS, Act 67 of 1885 provides that cities of the first class may vacate and abandon streets and roadways not required for municipal purposes; and

WHEREAS, the City Council of North Little Rock, Arkansas has considered the elimination of a certain street-railroad crossing over the Union Pacific Railroad (“UPRR”) in the City of North Little Rock (the “City”) (see diagrams collectively attached hereto as Exhibit A) which is not capable of use by vehicular traffic, serves no public purpose, and has been abandoned by the City, and has reached the following conclusions:

- 1) Vehicular access to the property formerly served by the crossing has been restricted for a period of time, resulting in the inability of vehicles to utilize the street-railroad crossing for any public purpose; and
- 2) The elimination of the existing street-railroad crossing and the bridge structure at 14th Street would accommodate safety for the citizens of the City.

WHEREAS, in consideration of the City agreeing to abandon and permanently vacate that portion of 14th Street crossing the UPRR right-of-way, UPRR agrees to pay the City \$75,000.00, to be paid when the street-railroad crossing has been removed and access to the railroad right-of-way has been barricaded, and to remove the bridge structure and to install permanent barricades at the UPRR right-of-way; and

WHEREAS, in consideration of the foregoing, the City Council believes that the existing street-railroad crossing at the intersection of 14th Street and the UPRR right-of-way (Department of Transportation No. 433920Y, at approximately Mile Post 344.40, Van Buren Subdivision) should be eliminated.

NOW, THEREFORE, BE IT ORDAINED BY THE CITY COUNCIL OF THE CITY OF NORTH LITTLE ROCK, ARKANSAS:

SECTION 1: That the street-railroad crossing formed by the intersection of 14th Street with the Union Pacific Railroad (Department of Transportation No. 433920Y, at approximately 344.40, Van Buren Subdivision), which is on the railroad right-of-way, is permanently vacated and abandoned, as it is no longer useable for municipal purposes, and the street-railroad crossing shall be permanently closed and eliminated.

SECTION 2: That the Mayor and City Clerk are hereby authorized to enter into a Railroad Highway Grade Crossing Closure agreement regarding the closure of the 14th Street property (substantially similar to Exhibit B attached hereto).

SECTION 3: That all ordinances or parts of ordinances in conflict herewith are hereby repealed to the extent of the conflict.

SECTION 4: That the provisions of this Ordinance are hereby declared to be severable and if any section, phrase or provision shall be declared or held invalid, such invalidity shall not affect the remainder of the sections, phrases or provisions.

SECTION 5: It is hereby found and declared that vacating, abandoning, and eliminating the street-railroad crossing formed by the intersection of 14th Street with the Union Pacific Railroad (Department of Transportation No. 433920Y, at approximately 344.40, Van Buren Subdivision) is immediately needed to remove existing hazards, and being necessary for the immediate preservation of the public health, safety and welfare; THEREFORE, an emergency is hereby declared to exist and this Ordinance shall be in full force and effect from and after its passage and approval.

PASSED:

APPROVED:

\_\_\_\_\_

\_\_\_\_\_

Mayor Joe A. Smith

SPONSOR:

ATTEST:

Joe A. Smith  
Mayor Joe A. Smith *by AF*

\_\_\_\_\_

Diane Whitbey, City Clerk

APPROVED AS TO FORM:

Amy Beckman Fields  
Amy Beckman Fields, City Attorney

PREPARED BY THE OFFICE OF THE CITY ATTORNEY/cf

FILED	<u>11:02</u>	A.M.	_____	P.M.
By	<u>A. Fields</u>			
DATE	<u>2-19-19</u>			
<b>Diane Whitbey, City Clerk and Collector North Little Rock, Arkansas</b>				
RECEIVED BY	<u>J. H. Sweeney</u>			



**BUILDING AMERICA®**

PROJECT: \_\_\_\_\_

SHEET NO. \_\_\_\_\_ OF \_\_\_\_\_ W.O. \_\_\_\_\_

CALCULATED BY \_\_\_\_\_ DATE \_\_\_\_\_

CHECKED BY \_\_\_\_\_ DATE \_\_\_\_\_

FILE NUMBER \_\_\_\_\_

NOTES:

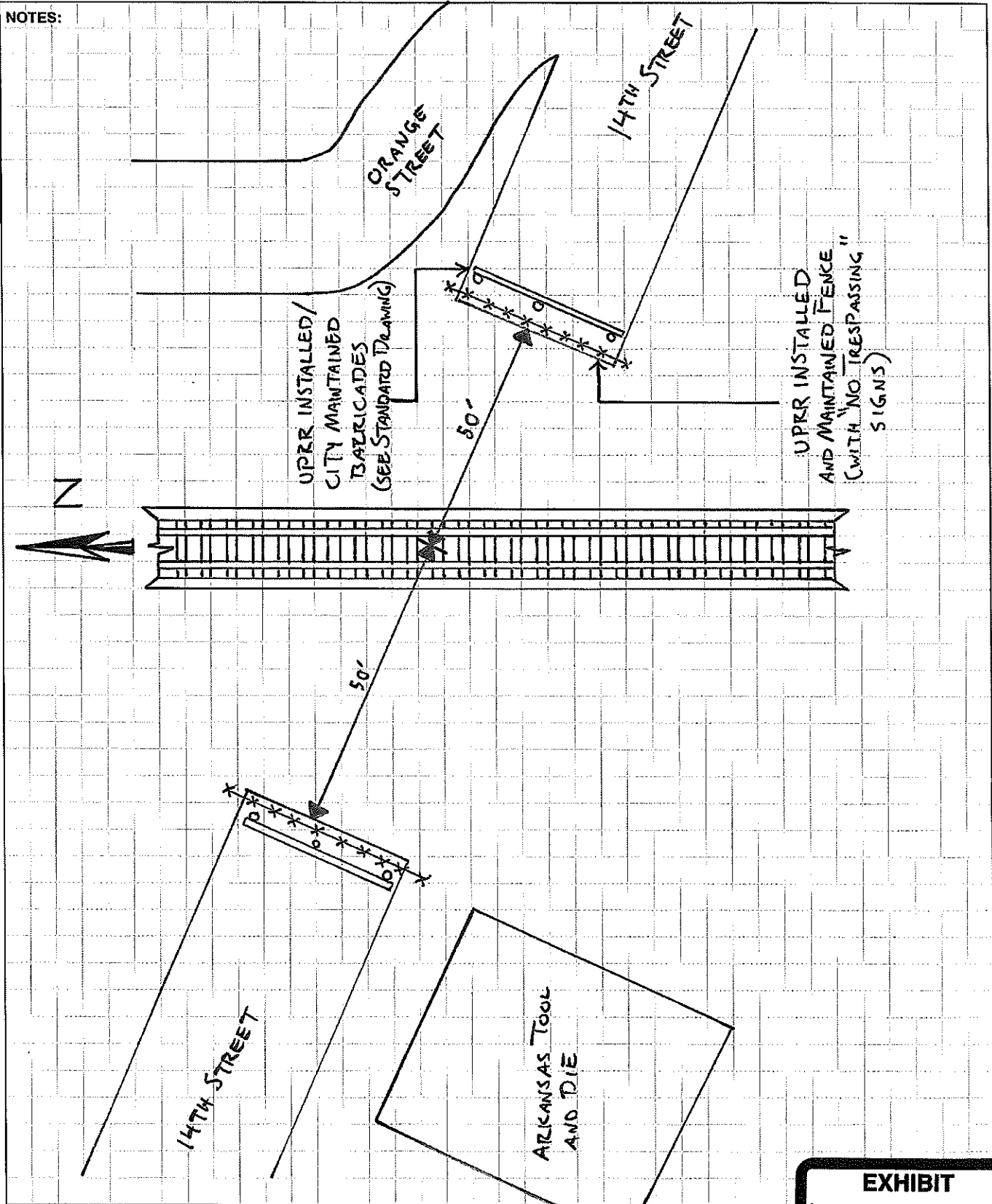

EXHIBIT

A.

tabbles

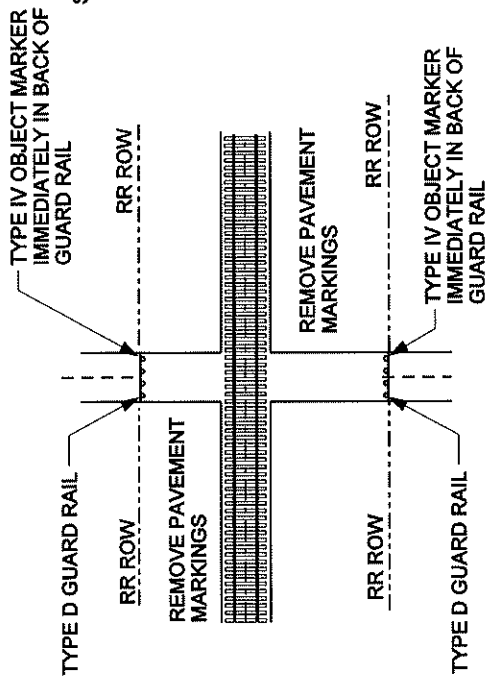

**TYPICAL ROAD CLOSED**

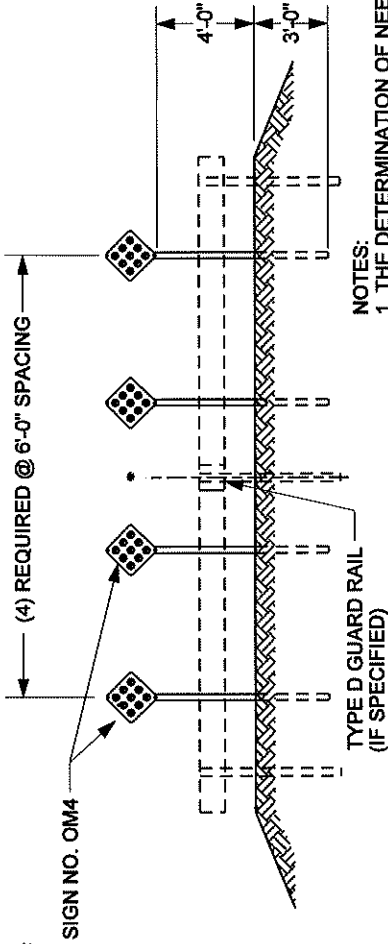

**MOUNTING DETAILS**  
**TYPE IV OBJECT MARKER - SIGN OM4**  
 (END OF ROAD OR STREET)

**NOTES:**  
 1. THE DETERMINATION OF NEED OF ANY BARRICADES ASSOCIATED WITH THE CLOSURE OF A PUBLIC ROADWAY WILL BE MADE BY THE STATE REGULATORY AGENCY OR THE PUBLIC ROAD AUTHORITY.

2. TYPE IV BARRICADES ARE TO ONLY BE USED WHEN A PUBLIC ROADWAY IS PERMANENTLY CLOSED TO ROADWAY USERS.
3. IT IS PERMISSIBLE TO UTILIZE A TYPE III BARRICADE WHEN SPECIFIED BY THE STATE REGULATORY AGENCY OR THE PUBLIC ROAD AUTHORITY.
4. WHEN SITE CONDITIONS WARRANT, BARRICADES CAN BE LOCATED OTHER THAN AT RIGHT OF WAY LINE WHEN SPECIFIED BY THE STATE REGULATORY AGENCY OR THE PUBLIC ROAD AUTHORITY.
5. POST MAY BE WOOD OR STEEL WITH ONLY ONE MATERIAL ALLOWED WITHIN A SINGLE PROJECT, EXCEPT FOR END TREATMENTS.
6. ALL DIMENSIONS ARE SUBJECT TO MANUFACTURER'S TOLERANCES EXCEPT WHERE ALLOWABLE TOLERANCES ARE SHOWN.
7. SEE PAGE 2 AND 3 FOR MORE DETAILS.

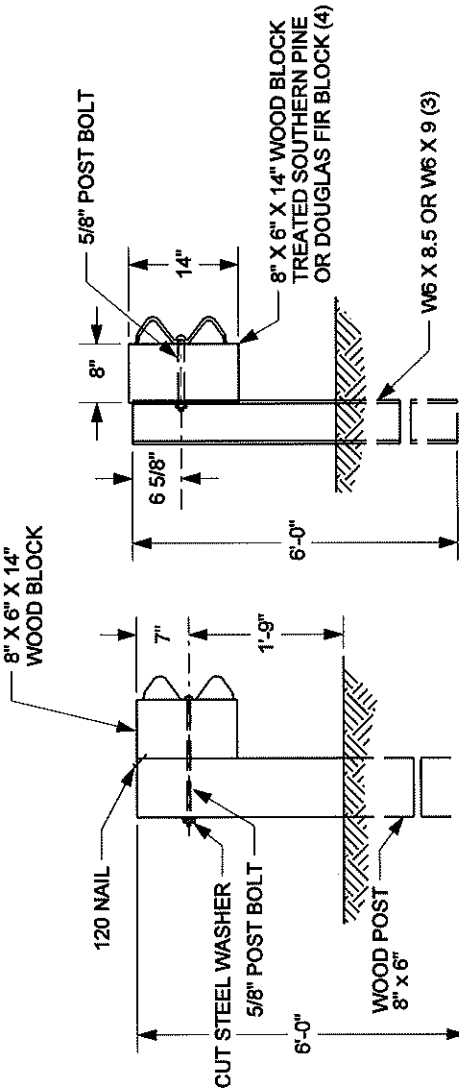

THE CONTRACTOR MAY FURNISH EQUIVALENT SECTIONS FABRICATED FROM MATERIAL MEETING AND IN ACCORDANCE WITH THE REQUIREMENTS OF ASTM A769 GRADE 36 OR 40. THE SECTIONS SHALL BE GALVANIZED AFTER FABRICATION IN ACCORDANCE WITH THE REQUIREMENTS OF AASHTO M111.

**WOOD POST & BLOCK**

**STEEL POST & WOOD BLOCK**

**UNION PACIFIC RAILROAD**  
**ENGINEERING STANDARDS**

**TYPE IV BARRICADE FOR**  
**ROAD CROSSING CLOSURE**



APPROVED: *Richard A. Condit*  
 VP ENGINEERING  
 ADOPTED: AUG. 14, 2009  
 REVISED:  
 FILE NO.: 0310

STD DWG  
 0310  
 PAGE 1 OF 3

STD DWG  
 0310  
 PAGE 1 OF 3

OPTIONAL 13/16" DIA. HOLE FOR HANDLING DURING GALVANIZING. (ONE PERMITTED)

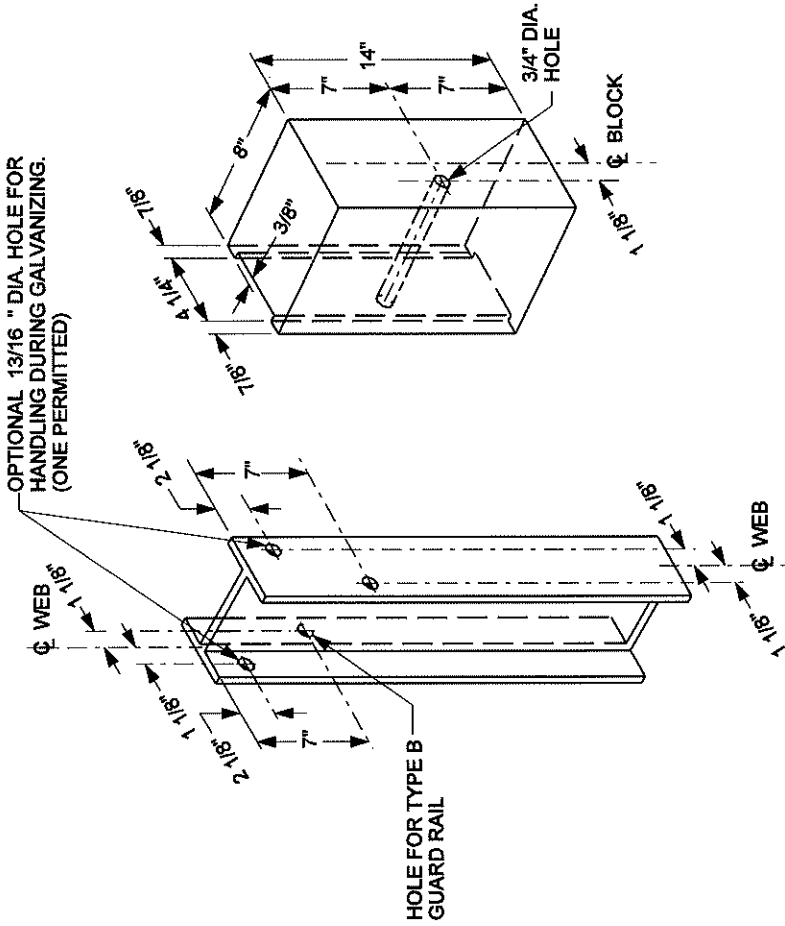

**HOLE DETAIL FOR STEEL POST & WOOD BLOCKS**

ALL HOLES 13/16" DIAMETER EXCEPT AS NOTED

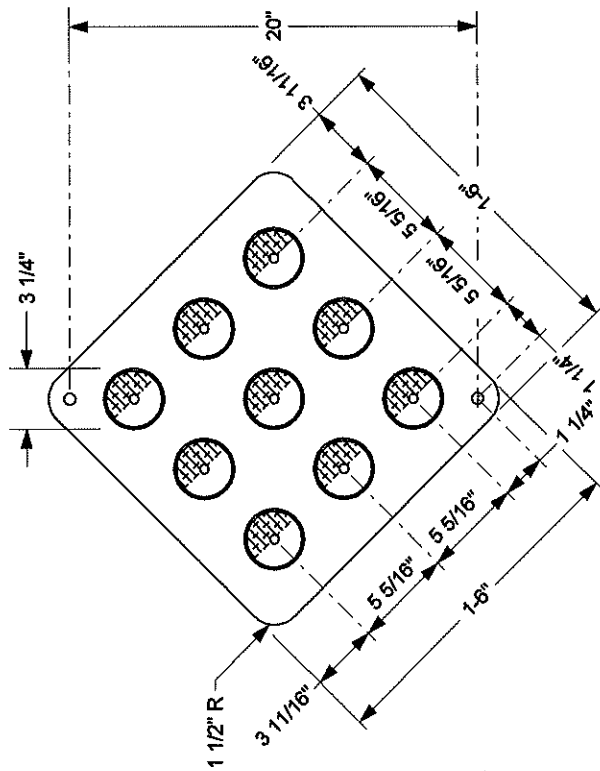

**SIGN OM4 DETAIL**

RED TYPE 2 REFLECTIVE SHEETING WITH RED REFLECTORS ON 0.063" THICK SHEET ALUMINUM WITH TWO 3/8" DIAMETER HOLES EACH.

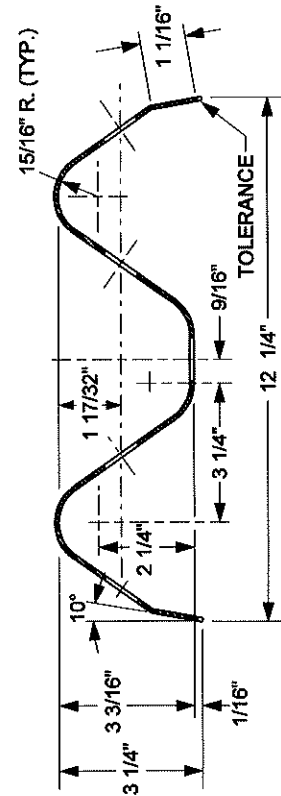

**SECTION THRU BEAM**

**UNION PACIFIC RAILROAD  
ENGINEERING STANDARDS**

**TYPE IV BARRICADE FOR  
ROAD CROSSING CLOSURE**

APPROVED: *[Signature]*  
VP ENGINEERING  
ADOPTED: AUG. 14, 2008  
REVISED:  
FILE NO.: 0310

STD DWG  
**0310**  
PAGE 2 OF 3

STD DWG  
**0310**  
PAGE 2 OF 3

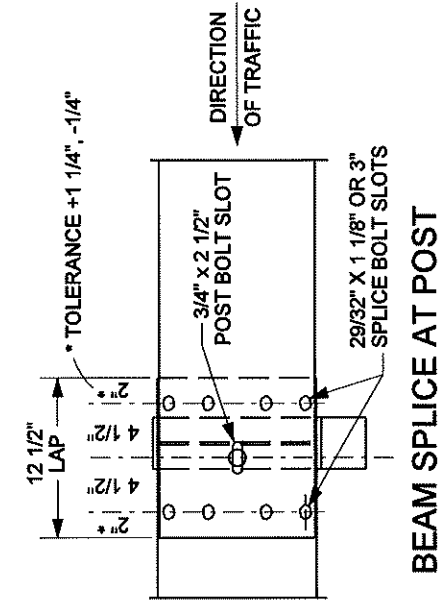

BEAM SPLICE AT POST

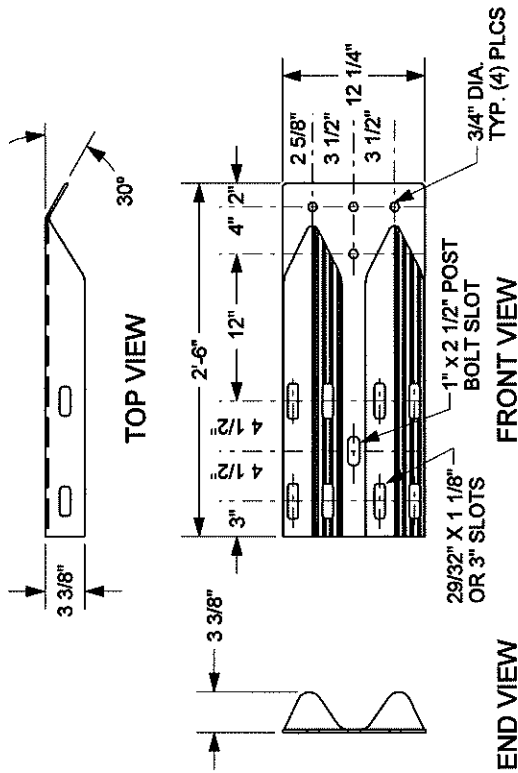

TERMINAL CONNECTOR

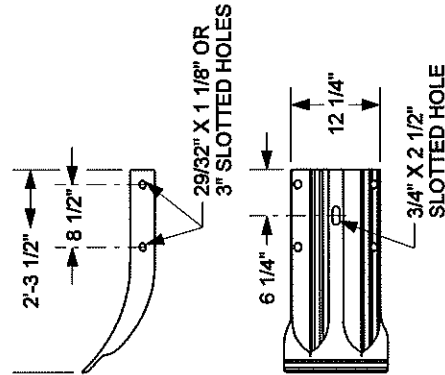

12 GAUGE  
END SECTION

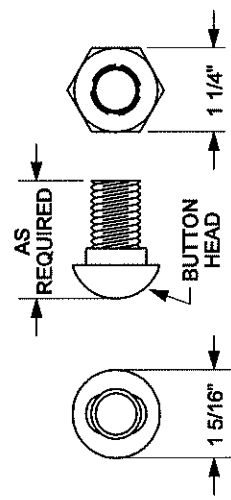

5/16" POST OR SPLICE BOLT

OVAL SHOULDER SHALL BE OF ADEQUATE HEIGHT, LENGTH & SHAPE TO PREVENT TURNING DURING INSTALLATION OR REMOVAL OF BOLT.

UNION PACIFIC RAILROAD  
ENGINEERING STANDARDS

TYPE IV BARRICADE FOR  
ROAD CROSSING CLOSURE

STD DWG  
0310  
PAGE 3 OF 3

APPROVED: *Richard J. Conner*  
VP ENGINEERING  
ADOPTED: AUG. 14, 2009  
REVISED:  
FILE NO.: 0310



STD DWG  
0310  
PAGE 3 OF 3

## AGREEMENT

RAILROAD HIGHWAY GRADE CROSSING CLOSURE  
PUBLIC GRADE CROSSING USDOT NO. 433920Y at RAILROAD MILEPOST 344.40  
VAN BUREN SUBDIVISION,  
CITY OF NORTH LITTLE ROCK, PULASKI COUNTY, STATE OF ARKANSAS

THIS AGREEMENT ("Agreement") is made and entered into this \_\_\_\_ day of \_\_\_\_\_, 2018 ("Effective Date") by and between **UNION PACIFIC RAILROAD COMPANY**, a Delaware corporation ("Railroad"), and **CITY OF NORTH LITTLE ROCK**, a municipal corporation of the State of ARKANSAS ("Public Authority"). **OR COUNTY OF PULASKI**, a political subdivision of the State of ARKANSAS ("Public Authority").

### RECITALS

The Public Authority desires to permanently close the at-grade public road crossing for 14th Street at Railroad Milepost 344.40, DOT No. 433920Y in the City of NORTH LITTLE ROCK County of PULASKI State of ARKANSAS on Railroad's VAN BUREN Subdivision (the "Roadway").

### AGREEMENT

NOW THEREFORE, It is mutually agreed by and between the Railroad and the Public Authority as follows:

**SECTION 1.** The Public Authority, after having executed this Agreement and after taking all actions necessary to permanently close and vacate the Roadway, easement and/or any other rights across the Railroad's property, will submit a billing statement in the amount of TWENTY THOUSAND DOLLARS (\$75,000.00) to the Railroad.

**SECTION 2.** The Railroad hereby agrees to pay the Public Authority the sum of \$75,000.00 upon (i) the receipt of the above mentioned billing statement and (ii) the receipt of a copy of the Ordinance or Resolution duly passed and adopted by the Public Authority that authorizes and directs the permanent closure of the Roadway.

**SECTION 3.** The Railroad, at its expense, further agrees to install permanent barricades, remove the railroad crossing surface, warning devices (crossbuck signs, etc.) and roadway surface which currently exist on the Railroad's right-of-way, upon the receipt of the above



mentioned statement and copy of the Ordinance or Resolution.

**SECTION 4.**

A. Prior to the Railroad's removal of the crossing surface and warning devices, the Public Authority agrees, at its expense, maintain, repair and renew permanent barricades on both sides of the Roadway with such barricades to be located off of the Railroad's property and to be in compliance with the plans marked **Exhibit A**, attached hereto and hereby made a part hereof, and also all applicable standards and guidelines contained in the current Manual on Uniform Traffic Control Devices ("MUTCD").

B. The Public Authority, at its expense, shall also (i) provide new advance street signs and pavement markings to indicate that the Roadway is closed, with such signage to be in compliance with applicable current MUTCD standards and guidelines.

IN WITNESS WHEREOF, the parties hereto have duly executed this Agreement as of the Effective Date first herein written.

UNION PACIFIC RAILROAD COMPANY

By: \_\_\_\_\_  
Printed Name: \_\_\_\_\_  
Title: \_\_\_\_\_

CITY OF NORTH LITTLE ROCK

By: \_\_\_\_\_  
Printed Name: \_\_\_\_\_  
Title: \_\_\_\_\_