

ORDINANCE NO. _____

AN ORDINANCE GRANTING A WAIVER OF SECTION 14.115 OF THE ZONING ORDINANCE TO ALLOW AN ELECTRONIC CHANGEABLE COPY SIGN ON CERTAIN REAL PROPERTY LOCATED AT 11601 KINARD ROAD IN THE CITY OF NORTH LITTLE ROCK, ARKANSAS; DECLARING AN EMERGENCY; AND FOR OTHER PURPOSES.

WHEREAS, a request has been made Rodney Pugh of Truckomat Corporation, P.O. Box 640, Walcott, Iowa 52773, to allow an electronic changeable copy message LED sign in a Highway 391 Overlay District to be located at 11601 Kindard Road (see letters from Rodney Pugh of Truckomat Corporation attached hereto as Exhibit A); and

WHEREAS, on July 23, 2018, the North Little Rock City Council (“City Council”) enacted Ordinance No. 9033, which amended Ordinance 7697 (the “Zoning Ordinance”) by adding Section 14.115 to the Zoning Ordinance, creating the Highway 391 Sign Overlay District; and

WHEREAS, Section 14.115 of the Zoning Ordinance permits electronic changeable copy signs within the Highway 391 Sign Overlay District; and

WHEREAS, the applicant seeks a waiver of the requirements pursuant to Section 14.115(D)(b) of the Zoning Ordinance which provides that signs shall be limited to a maximum of eighteen (18) feet in height; and

WHEREAS, the applicant seeks a waiver of the requirements pursuant to Section 14.115(D)(c) of the Zoning Ordinance which provides that signs shall be limited to a maximum of eighty-four (84) square feet; and

WHEREAS, a legal advertisement of notice of a public hearing to be held June 10, 2019 at 6:00 p.m. has been placed in the newspaper; and

WHEREAS, the request has not been reviewed by the Planning Commission, and applicant is seeking approval from the North Little Rock City Council.

NOW, THEREFORE, BE IT ORDAINED BY THE CITY COUNCIL OF THE CITY OF NORTH LITTLE ROCK, ARKANSAS:

SECTION 1: That the current sign is hereby permitted on real property located 11601 Kinard Road, being more particularly described as follows:

Lot 1, Truckomat Addition, North Little Rock, Pulaski County, Arkansas, (see map attached hereto as Exhibit B).

SECTION 2: That a waiver of the maximum sign height requirements of Section 14.115(D)(b) and sign square foot requirements Section 14.115(D)(c) of the Zoning Ordinance is

hereby granted for 11601 Kinard Road, North Little Rock, Pulaski County, Arkansas, to allow for a 501 square foot, 42 foot, 5 inch-tall ground mounted sign that includes a 5 foot, 9 inch by 12 foot cabinet electronic changeable copy sign (see images attached hereto as Exhibit C).

SECTION 3: That all ordinances or parts of ordinances in conflict herewith are hereby repealed to the extent of the conflict.

SECTION 4: That the provisions of this Ordinance are hereby declared to be severable and if any section, phrase or provision shall be declared or held invalid, such invalidity shall not affect the remainder of the sections, phrases or provisions.

SECTION 5: It is hereby found and determined that the herein-described sign on 11601 Kinard Road will not detract from the aesthetic appearance of the neighborhood or interfere with other development in the area, and that the immediate passage of this Ordinance is necessary in order to insure the proper and orderly growth and development of this land and the City of North Little Rock, Arkansas, and being necessary for the immediate preservation of the public health, safety and welfare, THEREFORE, an emergency is hereby declared to exist, and this Ordinance shall be in full force and effect from and after its passage and approval.

PASSED:

APPROVED:

Mayor Joe A. Smith

SPONSORS:

ATTEST:

Maurice Taylor
Council Member Maurice Taylor

Diane Whitbey, City Clerk

APPROVED AS TO FORM:

Amy Beckman Fields
Amy Beckman Fields, City Attorney

PREPARED BY THE OFFICE OF THE CITY ATTORNEY/cf

FILED	11:40	A.M.	_____	P.M.
By	<u>A. Fields</u>			
DATE	<u>6-4-19</u>			
Diane Whitbey, City Clerk and Collector				
North Little Rock, Arkansas				
RECEIVED BY	<u>Skssery</u>			

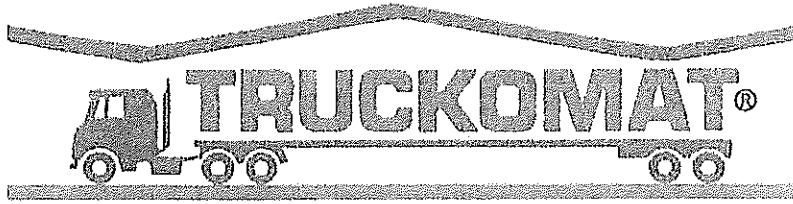

TRUCK WASH / FUELING CENTERS
I-80 and Exit 284 • P.O. Box 640
Walcott, Iowa 52773 • (563) 284-6965
FAX: (563) 284-6475

May 8, 2019

To: The City Of North Little Rock, Arkansas

RE: Change out old LED / ECC sign

Truckomat Corporation / North Little Rock Truckomat has owned and maintained a LED sign located on our property at the intersection of Kinard Road and Highway 391.

We are asking the city to allow us to change out this old ECC sign and install a new modern 5'9" x 12' cabinet ECC sign. Our old sign is outdated and the programming has become obsolete. It has become harder and more difficult to find parts to this sign.

The new ECC sign we are wanting to replace the old sign with, is considerably smaller in square footage.

Thank you for your consideration.

Rodney Pugh VP Operations
Truckomat Corporation / North Little Rock Truckomat.

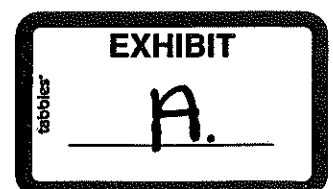



TRUCK WASH / FUELING CENTERS
I-80 and Exit 284 • P.O. Box 640
Walcott, Iowa 52773 • (563) 284-6965
FAX: (563) 284-6475

May 8, 2019

To: The City Of North Little Rock, Arkansas

RE: Acknowledgment Of ECC Signs and Rules

Truckomat management and staff will follow all rules enforced by the city of North Little Rock on operating a ECC sign. We have had our old ECC sign in place over ten years and have followed all rules in accordance with what the city of North Little Rock has in place.

We will continue to follow the rules the city has in place for the new ECC sign.

Signed Bruce Hensen General Manager North Little Rock Truckomat.

Bruce Hensen

Signed Rodney Pugh VP Operations Truckomat Corporation.

Rodney Pugh

Public Hearing Case # 2019-14

EXHIBIT
tabbles
B.

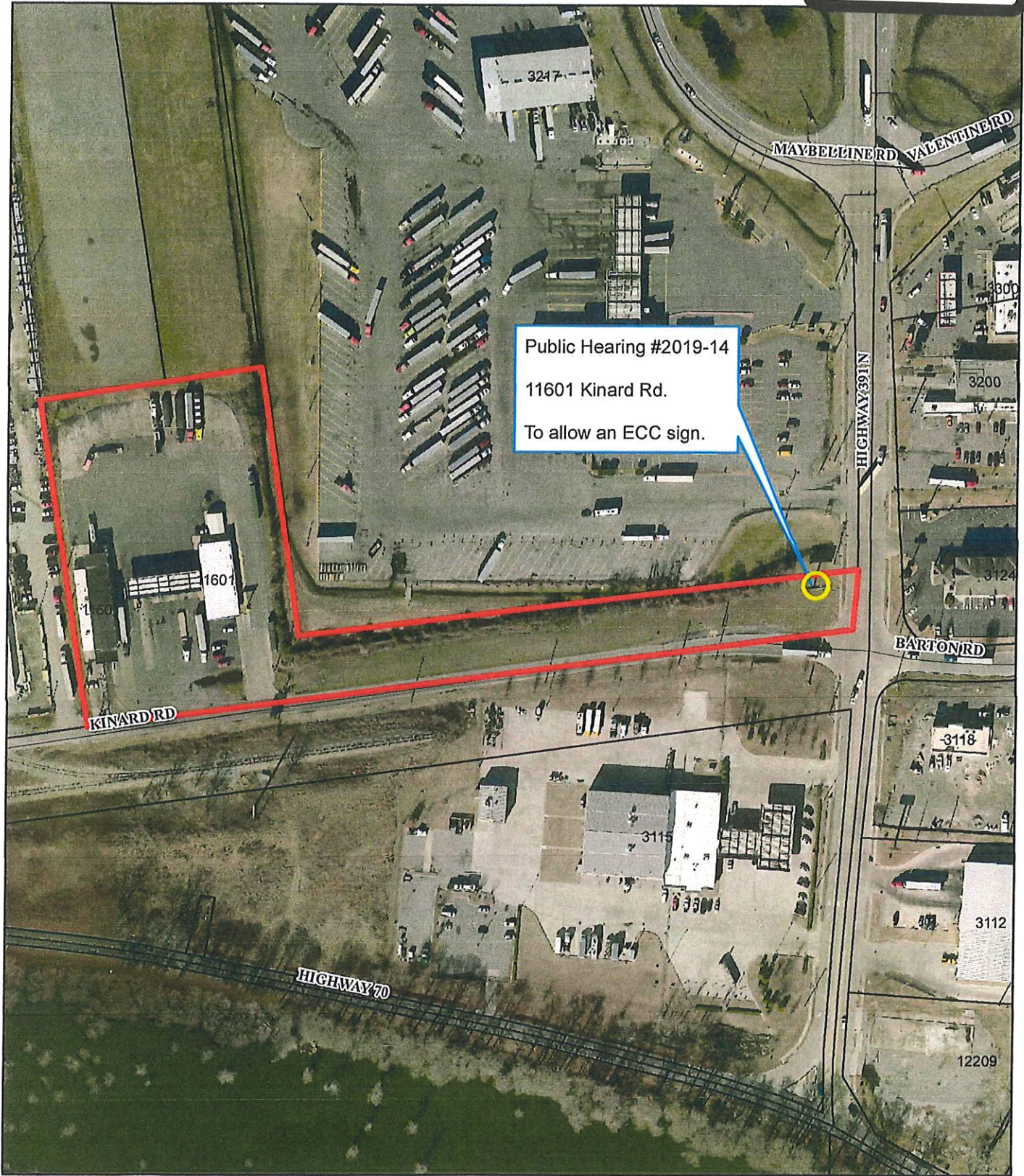

Ortho Map

1 inch = 200 feet



Date: 5/30/2019

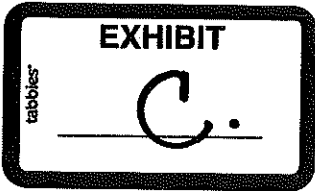

KEEPING OLD SIGN FACE
REMOVING CURRENT MESSAGE CENTER &
REPLACING WITH NEW MESSAGE CENTER

COPYRIGHT DOUBLED D SIGNS, INC.

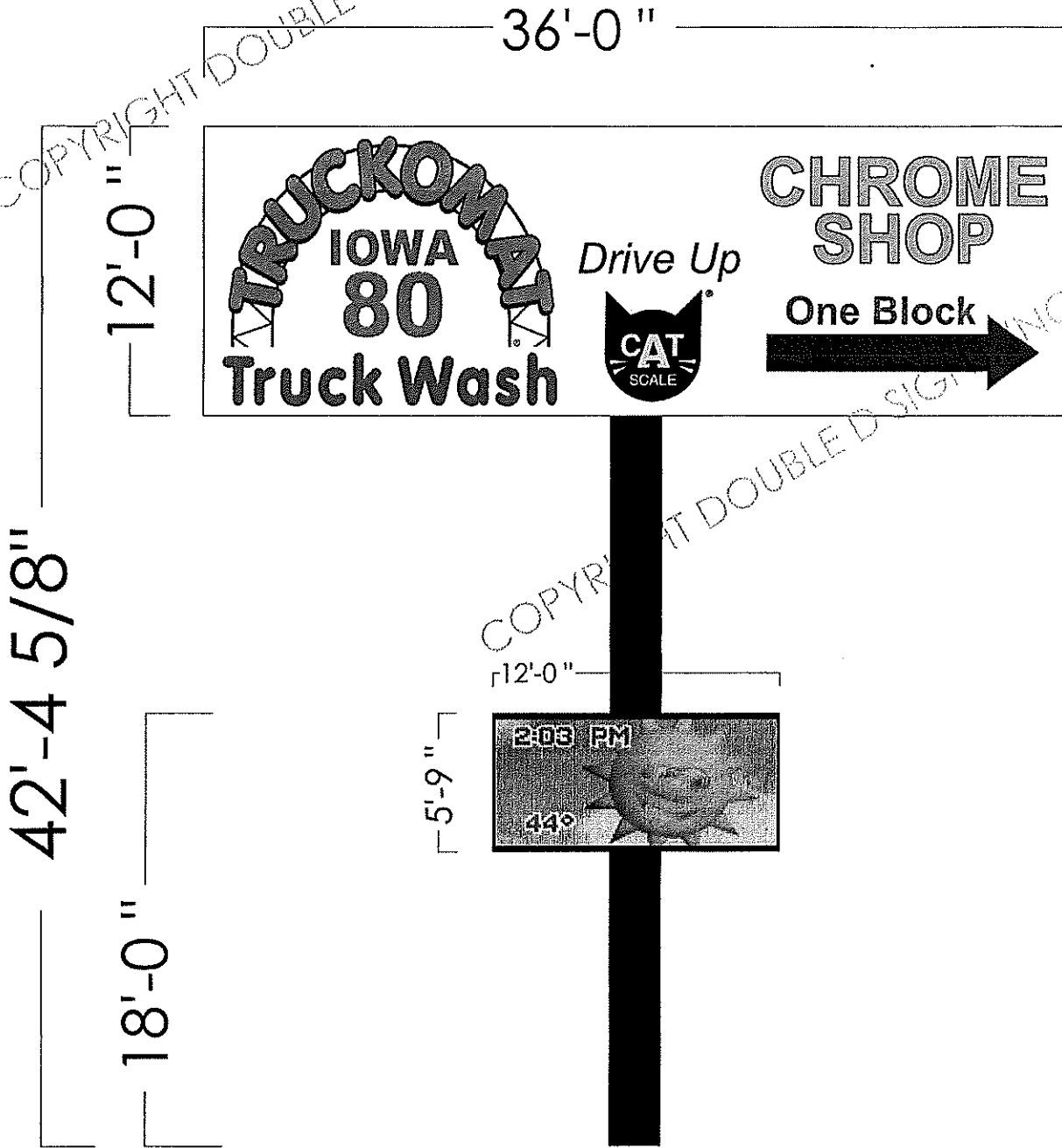

COPYRIGHT DOUBLED D SIGNS, INC.

**DOUBLE D
SIGNS,
INC.**

PROJECT NAME: *Truckomat Little Rock Arkansas*

DISCLAIMER: Exact color cannot be guaranteed. Please note that due to a variety of monitor settings, the artwork, as seen on your monitor, may slightly vary from the actual vinyl color. Your approval indicates that you are responsible for any changes to re-make or change a job in the event that you approved a proof that contained any errors (yours or ours). *Any disclosure, use, dissemination or copying of our files without first being purchased is strictly prohibited.

12548 N 1950th St.
Teutopolis, IL 62467
(217) 857-1662
signs@doubledsigns.com
www.doubledsigns.com